

# P&P

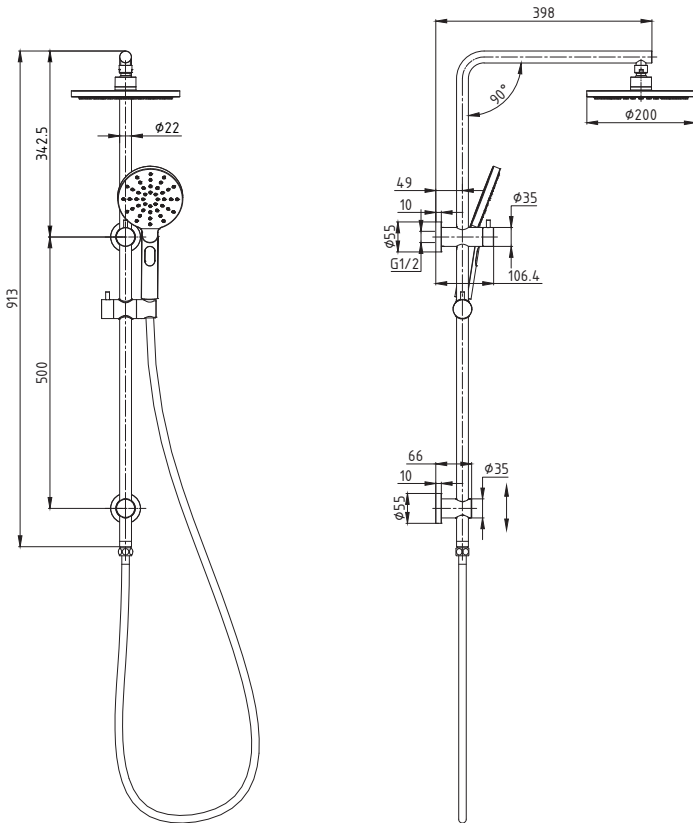

Available in



PHC4502RNS-B  
Matt Black



## Cora Round Multifunton Shower Set

PHC4502RNS

### Information

- FINISH: Chrome
- MATERIAL: Brass Rail
- OVER HEAD SIZE: 200mm
- HAND PIECE: 3 Functions
- SLIDER: 1/4 Turn Adjustable Slider
- HOSE: 1.5m Stainless Steel Hose (in Chrome)  
1.5m PVC Hose (in Matt Black)
- WELS: 3 STAR 8.5L/MIN (S17374)
- Diverter interchangeable between top or bottom inlet

### Maintenance and Care

- Do not use harsh detergents or products that contain chloride & halides.
- Do not use abrasive, cream or citrus based cleaners or hydrochloric acid.
- Surface should be cleaned only with a mild detergent that must be rinsed off.
- It is suggested to only clean with warm water and a soft cloth.
- Damage caused by the wrong cleaning methods used will void warranty.

Please visit <https://www.aclo.com.au/warranty.html> to view the full warranty